



CLESSE PART No.
006847CE

2nd Stage OPSO
300mbar 80kg/h 1,104kW

SUPPLIED BY
CLESSE
(UK) LIMITED

Over Pressure 'Pull to Reset' type with clear cap display

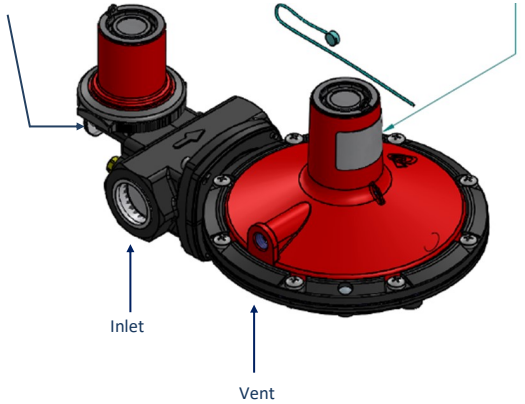

NOVACOMET BP24S-OPSO
 0.8+5 bar EN 16129
 300 mbar G.23/H.19
 PRV 420 mbar OPSO 475 mbar
 80 kg/h Propane (1104 kW)
 70 (N)m³/h NG (784 kW) **CE**

Technical Information

Regulator	BP24S OPSO
Capacity kg/h (kW) @ min inlet pressure	80 kg/h (1,104 kW)
Set Pressure	300 mbar (200 - 350)
Inlet Pressure(1st Stage)	0.8 bar (0.8-5 bar)
Limited relief Valve	420 mbar
OPSO Set Pressure	475 mbar
UPSO Pressure	n/a
Design Standard	BS EN16129 & CE
Inlet connection	Rc1F ISO/7 (BSP) (1")
Outlet connection	Rc1F ISO/7 (BSP) (1")

Item	Qty	Description
	1	BP24S 300mbar 2nd Stage Regulator 80kg/h

Assembly Instruction

1. Check the contents of the box ensuring, that the regulator meets the pressure and capacity of the installation, a visual inspection for damage and missing parts should also be completed.
2. This is a 2nd stage regulator and requires 1st Stage pressure reduction, according to the inlet pressure specification 0.8 - 5.0 bar. We recommend fitting a Clesse 1st stage to guarantee performance.
3. If the regulator is to be fitted as a wall mounted assembly, the pipework immediately before and after the regulator should be supported.
4. Ensure that the regulator vent faces downwards so that it does not collect rain water. See page 2 for instructions on how to rotate the vent.
5. Before fitting regulator to wall end PE kit, ensure that the pipe is clear of any debris. Clesse part code: 040911AB is recommended as an inlet filter.
6. Perform a gas tightness test to the requirements of UKLPG COP22 or BS 5482:1 – 2005, to suit the installation. Outlet pressure should be checked downstream of the regulator at high flow rates. The regulator does not come fitted with test points.
7. Fully commission assembly, checking operating pressures only when the appliances are available and connected. Otherwise, check for soundness and lockup before leaving. The regulator is pre-set at the factory and does not normally need adjustment when used.
8. Use Leak Detection Fluid on the test points and joints, checking for any leakage and wiping off any remaining residues. If not using LPG for test media, purge the assembly fully before leaving site.

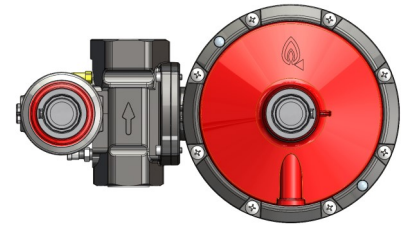

Install the regulator with vent pointing down or horizontal

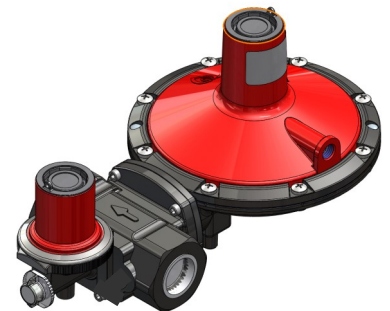

Useful Information

- This regulator is fitted with a limited relief valve and should be fitted outdoors.
- See overleaf for information on rotatable vent and diaphragm.

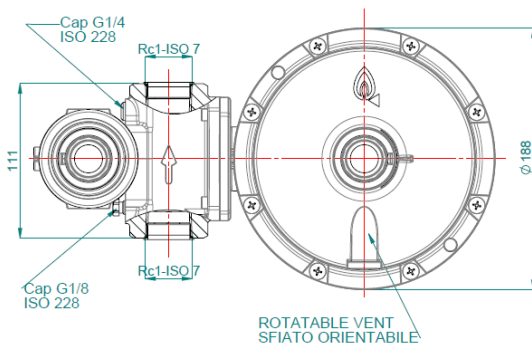

Performance in accordance with EN16129

Operating Conditions	Settings
Lock-up Pressure	350 mb or less
Operating pressure	300mb +/- 5mb
Operating temperature	-20°C to 45°C
Max Operating Inlet Pressure	2 bar
Maximum Incidental Pressure	5 bar
Optional pressure by replacement spring or ordering direct from Clesse (UK) Ltd	None
Special Builds & Assemblies with Meters Available	

Over Pressure Shut Off (OPSO) Reset

1. Over Pressure Shut Off must be reset by a qualified gas engineer, who should establish any cause for tripping, particularly if this device trips repeatedly.
2. The device is fitted with a sealing wire, this must be replaced when reset (not shown).
3. The upstream gas supply can remain off. Before re-establishing gas supply, ensure all downstream appliances and pipework are turned off.
4. Remove sealing wire and unscrew the OPSO reset cap; in doing so, this will begin to engage the reset spindle.
5. The OPSO cap is attached to the green reset indicator inside and is used to pull the device to reset. Pull the cap firmly.
6. When reset, replace cap, finger tighten, and reseal with new wire seal.
7. If the device continues to trip, consult your gas supplier or qualified engineer as soon as possible.

Unscrew OPSO cap reset and pull

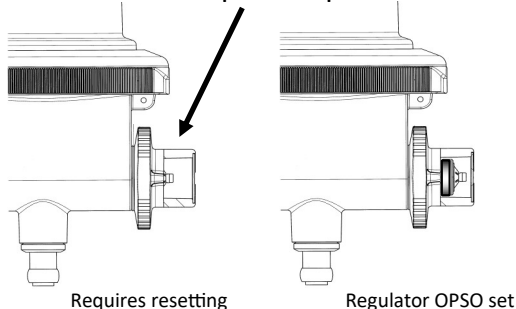

Vent orientation

Breather vent orientation is made easier by the Rotatable Vent cover, to prevent water from entering and/or accumulating in the regulator, either by rain, humidity, or condensation. The operation can be carried out on site by a qualified engineer.

1. Loosen the 8 screws, one by one.
2. Rotate and orientate the regulator cover with vent downward oriented.
3. Redo the 8 screws alternately.
4. Perform a leak test to ensure the installation is sound and the Rotatable Vent cover is sealed.



Rotatable Diaphragm Case

After installation into the pipework, it's easy to rotate the diaphragm casing to fit into confined spaces, or to position the vent downward as advised previously. Please proceed as follows:

1. Slack off (with a hexagon wrench), one by one, the 4 screws around the flange.
2. Rotate and orientate the diaphragm casing as necessary.
3. Redo the 4 screws alternately.
4. Perform a leak test to ensure the installation is sound and the Rotatable Vent cover is sealed.

